



# ***Polystyrene capacitors***

# Polystyrene capacitors

## Polystyrene capacitors



DIELECTRIC	POLYSTYRENE FILM FOIL (KS)					
Series	PLB/1	PLB/3	PLB/4	PLR	PLC	PLH
Capacitance range (μF)	0.0001 ÷ 0.01	0.0001 ÷ 0.0165	0.015 ÷ 0.034	0.0001 ÷ 0.603	0.0001 ÷ 0.603	0.00001 ÷ 0.047
Capacitance tolerance (+/- %)	0.5 ÷ 2.5	0.5 ÷ 2.5	0.5 ÷ 2.5	0.5 ÷ 2.5	0.5 ÷ 2.5	0.5 ÷ 2.5
Rated voltage Vdc	63	63	63	63 ÷ 1000	63 ÷ 1000	63 ÷ 2000
Pulse rise time (V/μs)						
Lead spacing mm	7.18	7.18	10.74	12.7 - 43.2	AXIAL	RADIAL LONG LEADS
Encapsulation	Potted with epoxy resin	Potted with epoxy resin	Potted with epoxy resin	Plastic wrapped and epoxy resin filled	Plastic wrapped and epoxy resin filled	Potted with epoxy resin
Climatic category acc.to IEC 60068-1	40/085/56	40/085/56	40/085/56	40/070/56	40/070/56	40/085/56
Packing	Bulk	Bulk	Bulk	Bulk	Bulk	Bulk
International standard	IEC 60384-7	IEC 60384-7	IEC 60384-7	IEC 60384-7	IEC 60384-7	IEC 60384-7

# Typical curves

Polystyrene capacitors

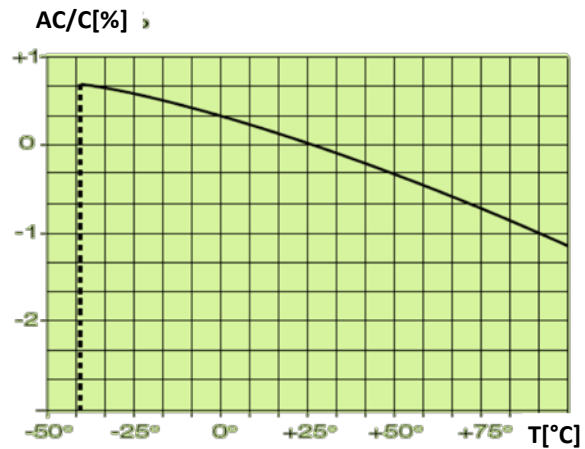

Capacitance variation as a function of temperature at 1 KHz

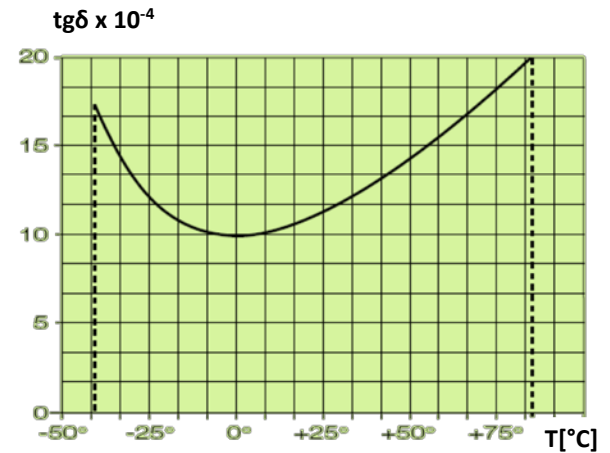

Dissipation factor variation as a function of temperature at 1 KHz

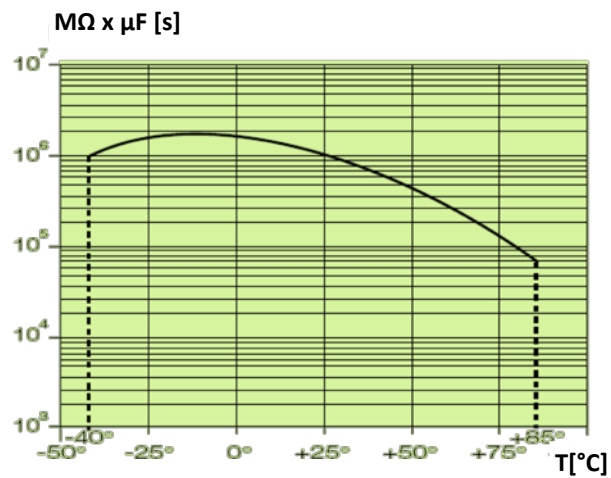

Insulation resistance variation as function of temperature

# Type PLB/1- PLB/3 - PLB/4

Polystyrene capacitors

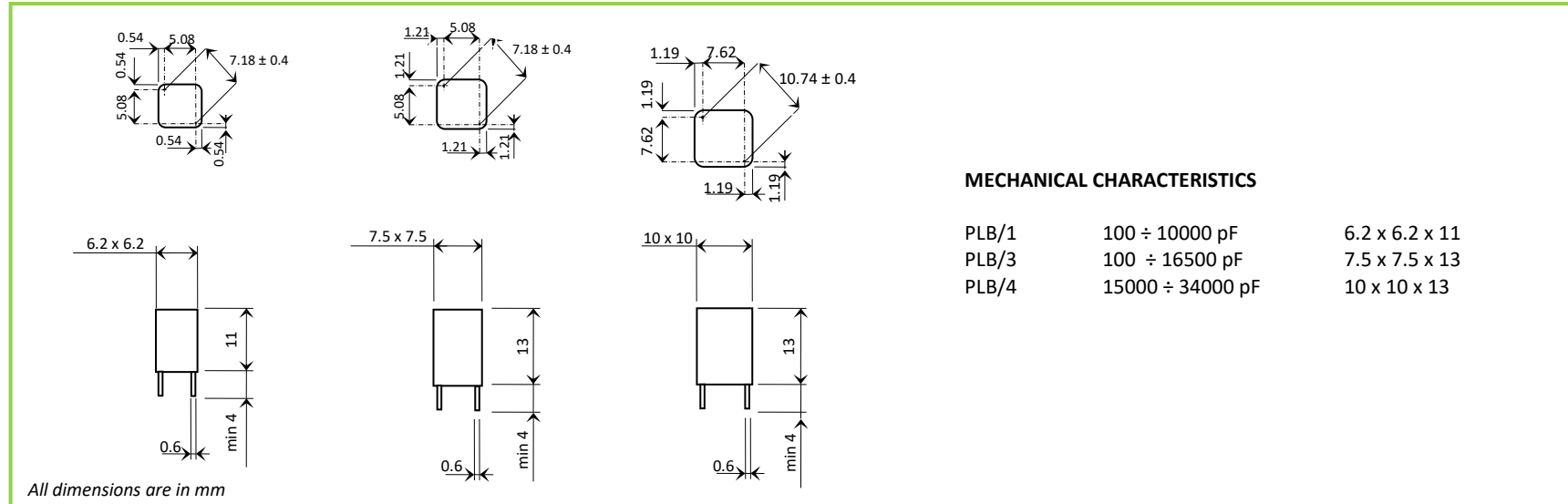

## MECHANICAL CHARACTERISTICS

PLB/1	100 ÷ 10000 pF	6.2 x 6.2 x 11
PLB/3	100 ÷ 16500 pF	7.5 x 7.5 x 13
PLB/4	15000 ÷ 34000 pF	10 x 10 x 13

## GENERAL TECHNICAL DATA

Dielectric	polystyrene film
Plates	tin foil
Winding	non-inductive type
Leads	tinned copper wire
Construction	radial leads, box type
Protection	plastic case, made of solvent resistant material, sealed with epoxy resin
Marking	outer foil, type, capacitance, tolerance, D.C. rated voltage
Climatic category	40/085/56 IEC 60068-1
Standard references	IEC 60384-7

# Type PLB/1- PLB/3 - PLB/4

## Polystyrene capacitors

ELECTRICAL CHARACTERISTICS			
Rated voltage (Vr)	63 Vdc	Dissipation factor (tgδ) At +25°C ±5°C	≤3 x 10 <sup>-4</sup> at 1 kHz
Category voltage (Vc)	up to 85 °C Vc = Vr	Insulation resistance	≥ 50 x 10 <sup>4</sup> MΩ
		Test conditions	Temperature: +25°C ±5°C Voltage charge time: 1 min Voltage charge: 50Vdc
Capacitance values	normal values in compliance with IEC standard series E12 - E24 - E48 - E96, E192(IEC 60063 Norm) <i>Other values available upon request</i>	Test voltage between terminals	2.5 x Vr applied for 2 s at 25 °C ±5 °C
Capacitance tolerances	±0.625% (A); ±1% (F); ±1.25% (E); ±2% (G); ±2.5% (H) with a min.; ±1 pF (Z) <i>measured at 1 kHz</i> <i>Other tolerances available upon request</i>	Reliability	ZR For PLB/1                      Z=30 FIT                      R=10 <sup>5</sup> hour For PLB/3                      Z=30 FIT                      R=10 <sup>5</sup> hour For PLB/4                      Z=80 FIT                      R=10 <sup>5</sup> hour 1 FIT = 1x10 <sup>-9</sup> failures/comp. x h
Total self-inductance (L)	max 1 nH per 1 mm lead and capacitor length		
Temperature coefficient	-(100 ±25) ppm/°C for C ≤ 1000 pF -(125 ±30) ppm/°C for C > 1000 pF		

QUALITY TEST			
Damp heat test	at temperature +40 ° ± 2° C, RH 93% ±2% , test duration 56 days capacitance change  ΔC/C  ≤ (0.75% + 1 pF) insulation resistance ≥ 5 x 10 <sup>4</sup> MΩ	Soldering	test IEC 60068-2-20 TB method 1A, solder bath at 260 °C ±5 °C for 5 s ±1 s ( with heat screen) capacitance change  ΔC/C  ≤ 0.2% + 0,2pF
Thermal shock	at temperature -40 °C...+85 °C, 5 cycles capacitance change  ΔC/C  ≤ (0.3% + 0.3 pF) for C ≤ 1000pF ; ±0.2% for C > 1000pF	Life test	at temperature +85 °C ± 2° C, voltage applied 1.5 x Vr, test duration 2000 h capacitance change  ΔC/C  ≤ 0.5% +0,5pF
Long term stability	at standard environmental conditions, test duration 2 years capacitance change  ΔC/C  ≤ (0.2% + 0.2 pF)		The typical capacitance variation after 8000 hours is ±0.6%

# Type PLR

## Polystyrene capacitors

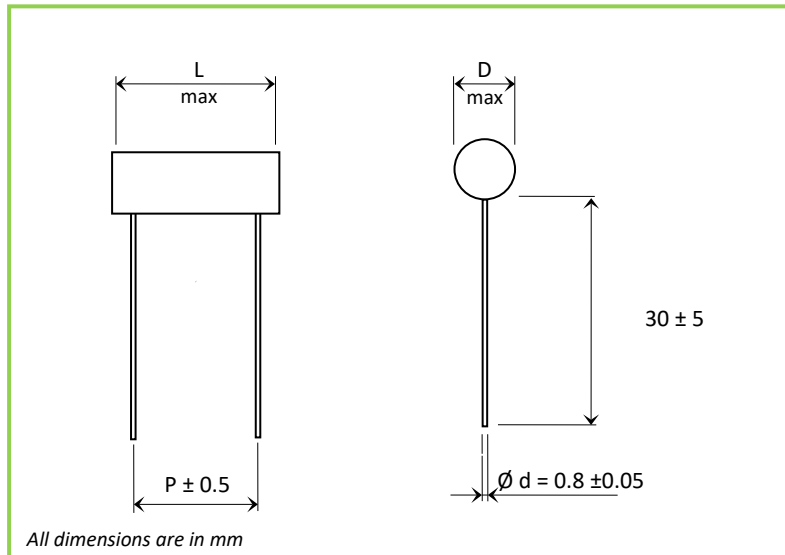

### GENERAL TECHNICAL DATA

Dielectric	polystyrene film
Plates	tin foil
Winding	non-inductive type
Leads	tinned copper wire
Construction	radial leads, cylindrical type
Protection	polyester wrapping sealed with epoxy resin
Marking	manufacturer's name or logo, outer foil, type, capacitance, tolerance, D.C. rated voltage and manufacturing date code
Climatic category	40/070/56 IEC 60068-1
Standard references	IEC 60384-7

### ELECTRICAL CHARACTERISTICS

Rated voltage (Vr)	63 Vdc - 100 Vdc - 250 Vdc - 630 Vdc - 1000 Vdc
Category voltage (Vc)	up to 70 °C Vc = Vr
Capacitance values	normal values in compliance with IEC standard series E12 - E24 - E48 - E96 - E192 (IEC 60063 Norm) <i>Other values available upon request</i>
Capacitance tolerances	± 0.625% (A); ±1% (F); ±1.25% (E); ±2% (G); ±2.5% (H) with a min. ± 1pF (Z) <i>measured at 1 kHz</i> <i>Other tolerances available upon request</i>
Total self-inductance	max 1 nH per 1 mm lead and capacitor length
Temperature coefficient	-(100±50) ppm/°C
Dissipation factor (tgδ)	≤ 5 x 10 <sup>-4</sup> at 1 kHz <i>At +25°C ±5°C</i>
Insulation resistance	≥ 50 x 10 <sup>4</sup> MΩ
<i>Test conditions</i>	<i>Temperature: +25°C ±5°C</i> <i>Voltage charge time: 1 min</i> <i>Voltage charge: 50Vdc for Vr=63Vdc and 100 Vdc for Vn≥100Vdc</i>
Test voltage between terminals	2.5 x Vr applied for 2 s at 25 °C ± 5 °C
Reliability	ZR L=300 FIT                      R=10 <sup>5</sup> hour 1 FIT = 1x10 <sup>-9</sup> failures/comp. x h

# Type PLR

## Polystyrene capacitors

QUALITY TEST			
Damp heat test	at temperature $+40^{\circ} \pm 2^{\circ} \text{C}$ , RH 93% $\pm 2\%$ , test duration 56 days capacitance change $ \Delta C/C  \leq (1\% + 1 \text{ pF})$ insulation resistance $\geq 5 \times 10^4 \text{ M}\Omega$	Soldering	test IEC 60068-2-20 TB method 1A, solder bath at $260^{\circ} \text{C} \pm 5^{\circ} \text{C}$ for $5 \text{ s} \pm 1 \text{ s}$ ( with heat screen) capacitance change $ \Delta C/C  \leq 0.5\% + 0,5\text{pF}$
Thermal shock	at temperature $-40^{\circ} \text{C} \dots +70^{\circ} \text{C}$ , 5 cycles capacitance change $ \Delta C/C  \leq (0.3\% + 0.3 \text{ pF})$ for $C \leq 1000\text{pF}$ ; $\pm 0.2\%$ for $C > 1000\text{pF}$	Life test	at temperature $+70^{\circ} \text{C} \pm 2^{\circ} \text{C}$ , voltage applied $1.5 \times V_r$ , test duration 2000 h capacitance change $ \Delta C/C  \leq 0.7\% + 0,7\text{pF}$
Long term stability	at standard environmental conditions, test duration 2 years capacitance change $ \Delta C/C  \leq (0.2\% + 0.2 \text{ pF})$		

63 Vdc			
Capacitance in pF	Dmax	Lmax	P
100 - 8200	7	17.5	12.7
8201 - 20000	9	17.5	12.7
20001 - 35000	11	17.5	12.7
35001 - 55000	13	17.5	12.7
55001 - 85000	13	22	17.8
85001 - 130000	15	22	17.8
130001 - 180000	16.5	22	17.8
180001 - 280000	16.5	27	22.9
280001 - 350000	19	27	22.9
350001 - 500000	19	32	27.9
500001 - 603000	22	32	27.9

100 Vdc			
Capacitance in pF	Dmax	Lmax	P
100 - 2500	7	17.5	12.7
2501 - 20000	9	17.5	12.7
20001 - 55000	11	22	17.8
55001 - 110000	13	27	22.9
110001 - 250000	15	32	27.9
250001 - 340000	16.5	38	33
340001 - 460000	16.5	48	43.2
460001 - 603000	16.5	48	43.2

250 Vdc			
Capacitance in pF	Dmax	Lmax	P
100 - 1000	7	17.5	12.7
1001 - 7000	9	17.5	12.7
7001 - 25000	11	22	17.8
25001 - 50000	13	27	22.9
50001 - 100000	15	32	27.9
100001 - 150000	16.5	38	33
150001 - 200000	16.5	48	43.2
200001 - 260000	19	48	43.2
260001 - 350000	22	48	43.2
350001 - 500000	25.5	48	43.2

All dimensions are in mm

630 Vdc			
Capacitance in pF	Dmax	Lmax	P
100 - 500	7	17.5	12.7
501 - 2500	9	17.5	12.7
2501 - 9500	11	22	17.8
9501 - 20000	13	27	22.9
20001 - 42000	15	32	27.9
42001 - 60000	17	38	33
60001 - 80000	17	48	43.2
80001 - 105000	19.5	48	43.2
105001 - 145000	22	48	43.2
145001 - 210000	26	48	43.2

1000 Vdc			
Capacitance in pF	Dmax	Lmax	P
100 - 500	7	17.5	12.7
501 - 1000	9	17.5	12.7
1001 - 4000	11	22	17.8
4001 - 10000	13	27	22.9
10001 - 20000	15	32	27.9
20001 - 35000	16.5	38	33
35001 - 50000	16.5	48	43.2

# Type PLC

## Polystyrene capacitors

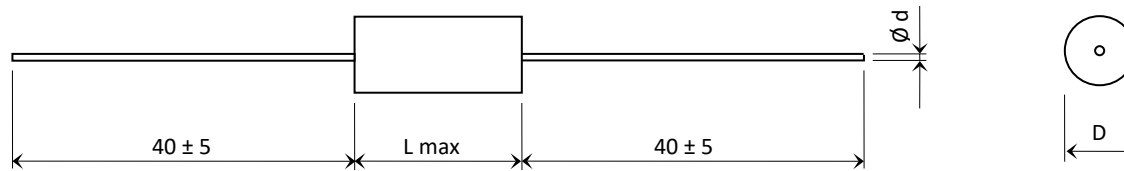

L 13 =  $\varnothing d 0.6 \pm 0.05$   
L >13 =  $\varnothing d 0.8 \pm 0.05$

All dimensions are in mm

### GENERAL TECHNICAL DATA

Dielectric	polystyrene film
Plates	tin foil
Winding	non-inductive type
Leads	tinned copper wire
Construction	axial leads, cylindrical type
Protection	polyester wrapping sealed with epoxy resin
Marking	manufacturer's name or logo, outer foil, type, capacitance, tolerance, D.C. rated voltage and manufacturing date code
Climatic category	40/070/56 IEC 60068-1
Standard references	IEC 60384-7

### ELECTRICAL CHARACTERISTICS

Rated voltage (Vr)	63 Vdc - 100 Vdc - 250 Vdc - 630 Vdc - 1000 Vdc
Category voltage (Vc)	up to 70 °C Vc = Vr
Capacitance values	normal values in compliance with IEC standard series E12 - E24 - E48 - E96 - E192 (IEC 60063 Norm) <i>Other values available upon request</i>
Capacitance tolerances	$\pm 0.625\%$ (A); $\pm 1\%$ (F); $\pm 1.25\%$ (E); $\pm 2\%$ (G); $\pm 2.5\%$ (H) with a min. $\pm 1\text{pF}$ (Z) <i>measured at 1 kHz</i> <i>Other tolerances available upon request</i>
Total self-inductance	max 1 nH per 1 mm lead and capacitor length
Temperature coefficient	$-(120 \pm 70)$ ppm/°C
Dissipation factor (tg $\delta$ )	$\leq 5 \times 10^{-4}$ at 1 kHz <i>At +25°C <math>\pm 5^\circ\text{C}</math></i>
Insulation resistance	$\geq 50 \times 10^4$ M $\Omega$ <i>Test conditions</i> <i>Temperature: +25°C <math>\pm 5^\circ\text{C}</math></i> <i>Voltage charge time: 1 min</i> <i>Voltage charge: 50Vdc for Vr=63Vdc and 100 Vdc for Vn<math>\geq</math>100Vdc</i>
Test voltage between terminals	2.5 x Vr applied for 2 s at 25 °C $\pm 5^\circ\text{C}$
Reliability	ZR Z=80 FIT R=10 <sup>5</sup> hour 1 FIT = 1x10 <sup>-9</sup> failures/comp. x h



# Type PLC

## Polystyrene capacitors

QUALITY TEST			
Damp heat test	at temperature $+40^{\circ} \pm 2^{\circ} \text{C}$ , RH 93% $\pm 2\%$ , test duration 56 days capacitance change $ \Delta C/C  \leq (1\% + 1 \text{ pF})$ insulation resistance $\geq 5 \times 10^4 \text{ M}\Omega$	Soldering	test IEC 60068-2-20 TB method 1A, solder bath at $260^{\circ} \text{C} \pm 5^{\circ} \text{C}$ for $5 \text{ s} \pm 1 \text{ s}$ ( with heat screen) capacitance change $ \Delta C/C  \leq 0.5\% + 0,5\text{pF}$
Thermal shock	at temperature $-40^{\circ} \text{C} \dots +70^{\circ} \text{C}$ , 5 cycles capacitance change $ \Delta C/C  \leq (0.3\% + 0.3 \text{ pF})$ for $C \leq 1000\text{pF}$ ; $\pm 0.2\%$ for $C > 1000\text{pF}$	Life test	at temperature $+70^{\circ} \text{C} \pm 2^{\circ} \text{C}$ , voltage applied $1.5 \times V_r$ , test duration 2000 h capacitance change $ \Delta C/C  \leq 0.7\% + 0,7\text{pF}$
Long term stability	at standard environmental conditions, test duration 2 years capacitance change $ \Delta C/C  \leq (0.2\% + 0.2 \text{ pF})$		

63 Vdc		
Capacitance in pF	Dmax	Lmax
100 - 16000	6.5	13
16001 - 20000	9	17.5
20001 - 35000	11	17.5
35001 - 55000	13	17.5
55001 - 85000	13	22
85001 - 130000	15	22
130001 - 180000	16.5	22
180001 - 280000	16.5	27
280001 - 350000	19	27
350001 - 500000	19	32
500001 - 603000	22	32

100 Vdc		
Capacitance in pF	Dmax	Lmax
100 - 2500	7	17.5
2501 - 20000	9	17.5
20001 - 55000	11	22
55001 - 110000	13	27
110001 - 250000	15	32
250001 - 340000	16.5	38
340001 - 460000	16.5	48
460001 - 603000	16.5	48

250 Vdc		
Capacitance in pF	Dmax	Lmax
100 - 1000	7	17.5
1001 - 7000	9	17.5
7001 - 25000	11	22
25001 - 50000	13	27
50001 - 100000	15	32
100001 - 150000	16.5	38
150001 - 200000	16.5	48
200001 - 260000	19	48
260001 - 350000	22	48
350001 - 500000	25.5	48

All dimensions are in mm

630 Vdc		
Capacitance in pF	Dmax	Lmax
100 - 500	7	17.5
501 - 2500	9	17.5
2501 - 9500	11	22
9501 - 20000	13	27
20001 - 42000	15	32
42001 - 60000	17	38
60001 - 80000	17	48
80001 - 105000	19.5	48
105001 - 145000	22	48
145001 - 210000	26	48

1000 Vdc		
Capacitance in pF	Dmax	Lmax
100 - 500	7	17.5
501 - 1000	9	17.5
1001 - 4000	11	22
4001 - 10000	13	27
10001 - 20000	15	32
20001 - 35000	16.5	38
35001 - 50000	16.5	48

# Type PLH

## Polystyrene capacitors

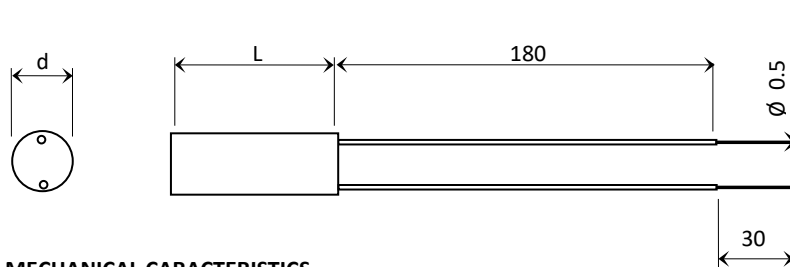

### MECHANICAL CHARACTERISTICS

	L x D
10 pF ÷ 9900 pF	36.5mm x 11.5 mm
10 nF ÷ 24 nF	35 mm x 15 mm
25 nF ÷ 28 nF	40 mm x 15 mm
29 nF ÷ 47 nF	57 mm x 16.5 mm

All dimensions are in mm

### GENERAL TECHNICAL DATA

Dielectric	polystyrene film
Plates	tin foil
Winding	non-inductive type
Leads	insulated flexible leads
Construction	cylindrical type
Protection	plastic tube sealed with epoxy resin
Marking	manufacturer's name or logo, outer foil, type, capacitance, tolerance, D.C. rated voltage and manufacturing date code
Climatic category	40/085/56 IEC 60068-1
Standard references	IEC 60068-1; IEC 60068-2

### ELECTRICAL CHARACTERISTICS

Rated voltage (Vr)	750 Vdc - 1000 Vdc - 2000 Vdc
Category voltage (Vc)	up to 85 °C Vc = Vr
Capacitance values	normal values in compliance with IEC standard series E6 (IEC 60063 Norm)
Capacitance tolerances	± 0.625% (A); ±1% (F); ±1.25% (E); ±2% (G); ±2.5% (H) with a min. ± 1pF (Z) <i>measured at 1 kHz</i> <i>Other tolerances available upon request</i>
Total self-inductance	max 1 nH per 1 mm lead and capacitor length
Temperature coefficient	1 nF < C ≤ 47 nF - (125±30) ppm / °C
Dissipation factor (tgδ) At +25°C ±5°C	≤ 5 x 10 <sup>-4</sup> at 1 kHz for C > 1000 pF ≤ 10 x 10 <sup>-4</sup> at 100 kHz for C ≤ 1000 pF
Insulation resistance	≥ 50 x 10 <sup>4</sup> MΩ
<i>Test conditions</i>	<i>Temperature: +25°C ±5°C</i> <i>Voltage charge time: 1 min</i> <i>Voltage charge: 100Vdc</i>
Test voltage between terminals	2.5 x Vr applied for 2 s at 25 °C ±5 °C
Test voltage between case and terminals	2500 Vdc

### QUALITY TEST

Damp heat test	at temperature +40 ° ± 2° C, RH 93% ±2% , test duration 56 days capacitance change  ΔC/C  ≤ (1% + 1 pF) insulation resistance ≥ 5 x 10 <sup>4</sup> MΩ
Climatic sequency	Test IEC 60068 Ba dry heat Test IEC 60068 D damp heat Test IEC 60068 Aa cold
Long term stability	at standard environmental conditions, test duration 2 years capacitance change  ΔC/C  ≤ (0.2% + 0.2 pF)
Soldering	test IEC 60068-2-20 TB method 1A, solder bath at 260 °C ±5 °C for 5 s ±1 s ( with heat screen) capacitance change  ΔC/C  ≤ 0.5% + 0,5pF
Life test	at temperature +85 °C ± 2° C, voltage applied 1.5 x Vr, test duration 2000 h capacitance change  ΔC/C  ≤ 0.7% +0,7pF